

STEEL UPPER BAIL - SM-UB-40

APPROX WEIGHT: 16.44 lbs.
 DOES NOT INCLUDE WEIGHT OF POWER OR PACKAGING!!!

*** ANY ADDITIONS, DELETIONS, OR OMISSIONS MUST BE CORRECTED ON THIS DRAWING AS THIS DRAWING WILL BE CONSIDERED ALL INCLUSIVE ***

ALL GRAPHICS PROVIDED ARE FOR REFERENCE ONLY. IF CERTAIN DIMENSIONS ARE CRITICAL PLEASE VERIFY THOSE DIMENSIONS WITH YOUR SALESPERSON

LIFTING EQUIPMENT
 ATTACHES HERE
 ON UPPER BAILS

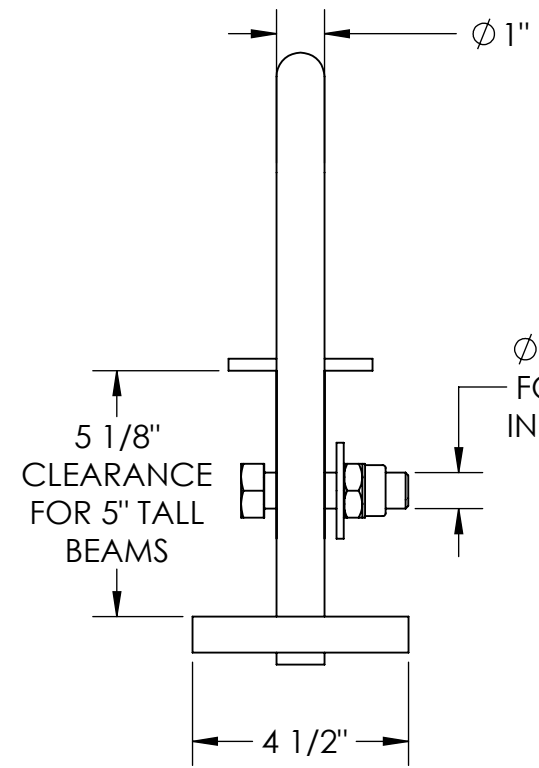
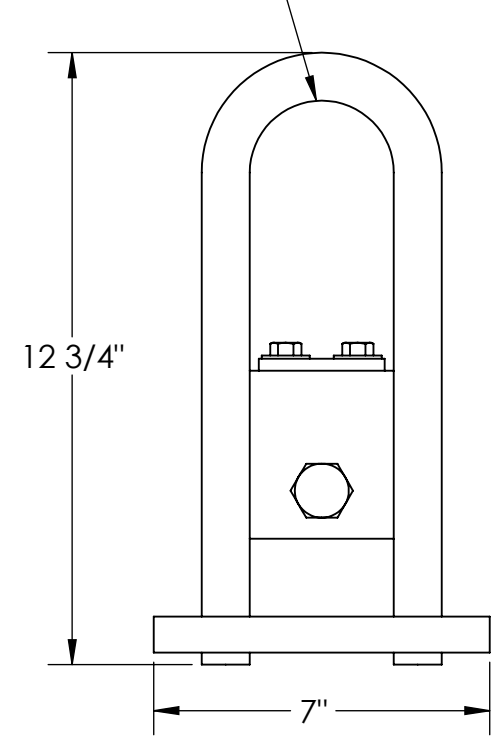

TOP RETAINING PLATE
 PREVENTS UPPER BAIL
 FROM DROPPING OUT
 OF SPREADER BEAM

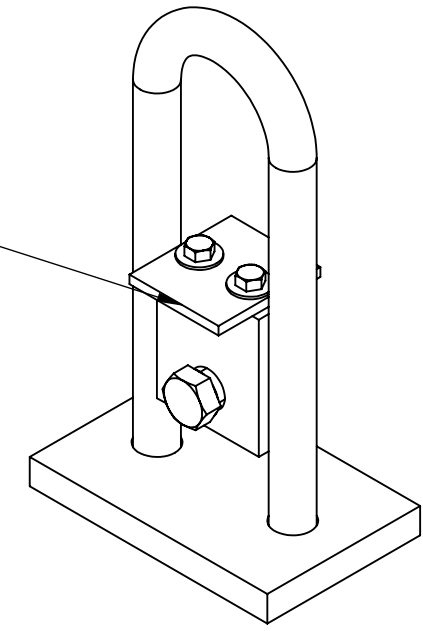

$\phi 3/4''$ BOLT (REMOVABLE)
 FOR POSITIONING BAIL
 IN SPREADER BEAM

DIMENSION TOLERANCE $\pm 1/4''$

STANDARD FEATURES

- MODEL NUMBER IS SM-UB-40
- FOR USE WITH ADJUSTABLE SPREADER BEAM SBM-40
- OVERALL WIDTH IS 7"
- OVERALL LENGTH IS 4 1/2"
- OVERALL HEIGHT IS 12 3/4"
- MAX CAPACITY IS 4,000 LBS
- INCLUDES REMOVABLE $\phi 3/4''$ BOLT FOR POSITIONING
- TOUGH BAKED IN POWDER COATED BLUE FINISH

SPECIAL FEATURES

NONE

APPROVAL	I, THE UNDERSIGNED, AGREE THAT THE PRODUCT AS REPRESENTED SATISFIES DESIGN AND DIMENSION REQUIREMENTS. I ALSO ACKNOWLEDGE MY DUTY TO CONFIRM PRODUCT AND INSTALLATION COMPLIANCE WITH ALL APPLICABLE FEDERAL, STATE AND LOCAL REGULATIONS AND STANDARDS.	
	UNITS REQUIRING APPROVAL DRAWINGS OR MODIFIED ARE NON-RETURNABLE	
	[] As drawn [] As marked	
Signed: _____		Date: _____
Printed Name: _____		
<i>LEAD TIME WILL START UPON RECEIPT OF SIGNED APPROVAL DRAWING</i>		

DISTRIBUTOR'S NAME:		P.O.#
VESTIL MANUFACTURING		X
DRAWN BY: MTS		W.O.#
DATE: 10/03/2023		X
REFERENCE: X	SCALE: 1:4	SALES: X
QUOTED LEAD TIME: X	QUOTE # X	FILE NAME:
		43-007-034